

MVN SÜPER HASSAS MENGENE

TEKNİK ÖZELLİKLERİ

- YÜKSEK KALİTELİ ALAŞIMLI ÇELİKTE ÜRETİLMİŞTİR
- PARALELLİK TOLERANSI 0,0015 mm / 100 mm, KARESELLİK TOLERANSI 0,03mm
- ÇALIŞMA YÜZEYLERİ 56-60 HRC ŞERTLEŞTİRİLİP HASSAS TAŞLANMIŞTIR
- HAREKETLİ ÇENE HIZLI AYARLANABİLİR VE KOLAY KULLANILIR
- CNC İŞLEME MERKEZLERİNDE VE DİĞER HASSAS TEZGAHLARDA KULLANILIR

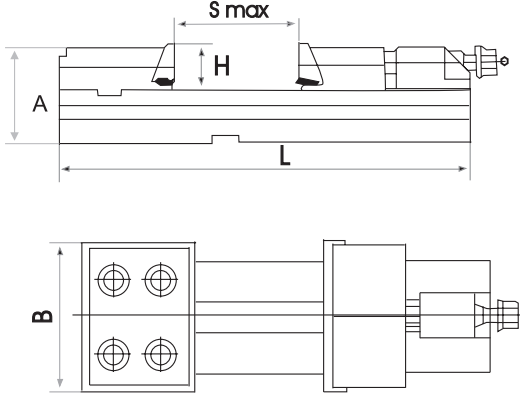

KOD	B (mm)	H (mm)	A (mm)	S max. (mm)	L (mm)	AĞIRLIK (Kg)	FİYAT USD
C970-MVN125	125	40	82	140	323	14,5	
C970-MVN150	150	52	103	210	423	28	
C970-MVN175	175	58	116	240	470	38	
C970-MVN200	200	66	132	270	520	51	
C970-MVN250	250	74	148	340	600	78	

MVN SÜPER HASSAS MENGENE YEDEKLERİ



VİDA BLOĞU

ÖLÇÜ (mm)	FİYAT USD
125	
150	
175	
200	
250	



HAREKETLİ ÇENE

ÖLÇÜ (mm)	FİYAT USD
125	
150	
175	
200	
250	



SABİT ÇENE

ÖLÇÜ (mm)	FİYAT USD
125	
150	
175	
200	
250	



HAREKETLİ ÇENE PLEYTİ

ÖLÇÜ (mm)	FİYAT USD
125	
150	
175	
200	
250	



SABİT ÇENE PLEYTİ

ÖLÇÜ (mm)	FİYAT USD
125	
150	
175	
200	
250	



MENGENE VİDASI

ÖLÇÜ (mm)	FİYAT USD
125	
150	
175	
200	
250	

SÜPER HASSAS MENGENE

TEKNİK ÖZELLİKLERİ

- YÜKSEK KALİTELİ ALAŞIMLI ÇELİKTE ÜRETİLMİŞTİR
- PARALELLİK TOLERANSI 0,005 mm / 100 mm
- ÇALIŞMA YÜZEYLERİ 58-62 HRC ŞERTLEŞTİRİLİP HASSAS TAŞLANMIŞTIR
- HAREKETLİ ÇENE HIZLI AYARLANABİLİR VE KOLAY KULLANILIR
- CNC İŞLEME MERKEZLERİNDE VE DİĞER HASSAS TEZGAHLARDA KULLANILIR

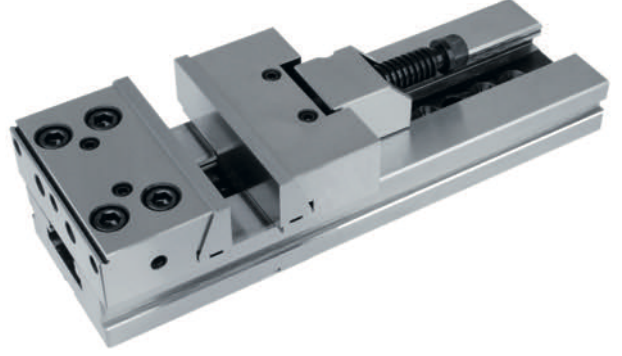
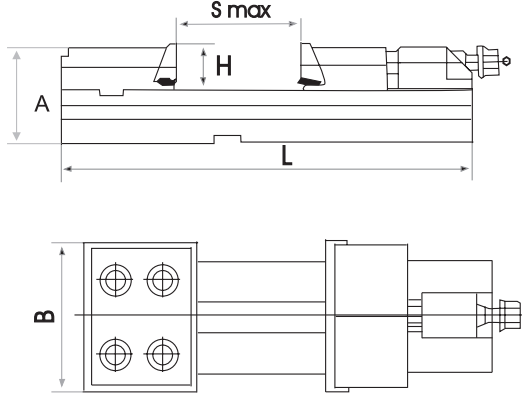

KOD	B (mm)	H (mm)	A (mm)	S max. (mm)	L (mm)	BASMA KUVVETİ (Kg)	AĞIRLIK (Kg)	FİYAT USD
C970-125X150	125	40	85	150	345	3000	12,7	
C970-150X200	150	50	105	200	420	5000	25,6	
C970-150X300		50	105	300	520	5000	29,5	
C970-175X200	175	60	120	200	455	6000	33,8	
C970-175X300		60	120	300	555	6000	42,5	
C970-200X300	200	65	135	300	595	10000	64,0	
C970-200X400		65	135	400	695	10000	71,0	
C970-200X500		65	135	500	795	10000	78,0	
C970-200X600		65	135	600	895	10000	85,0	
C970-300X400	300	80	160	400	735	120000	100,0	
C970-300X500		80	160	500	835	120000	120,0	

SÜPER HASSAS MENGENESİ İÇİN DÖNER TABLA

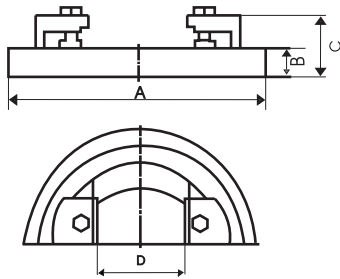

KOD	A (mm)	B (mm)	C (mm)	D (mm)	FİYAT USD
C971-125	226	23	47	95	
C971-150	290	28	58	125	
C971-175	320	28	58	145	
C971-200	370	34	74	170	
C971-300	400	38	78	195	

SÜPER HASSAS MENGENE YEDEKLERİ

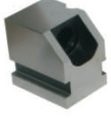

VİDA BLOĞU

ÖLÇÜ (mm)	FİYAT USD
125	
150	
175	
200	
300	



HAREKETLİ ÇENE

ÖLÇÜ (mm)	FİYAT USD
125	
150	
175	
200	
300	



SABİT ÇENE

ÖLÇÜ (mm)	FİYAT USD
125	
150	
175	
200	
300	



HAREKETLİ ÇENE PLEYTİ

ÖLÇÜ (mm)	FİYAT USD
125	
150	
175	
200	
300	



SABİT ÇENE PLEYTİ

ÖLÇÜ (mm)	FİYAT USD
125	
150	
175	
200	
300	



MENGENE VİDASI

ÖLÇÜ (mm)	FİYAT USD
125	
150	
175	
200	
300	



KİLİTLEME CİVATASI

ÖLÇÜ (mm)	FİYAT USD
125	
150	
175	
200	
300	



MENGENE KOLU

ÖLÇÜ (mm)	FİYAT USD
125	
150	
175	
200	
300	

MODÜLER SÜPER HASSAS MENGENE HAREKETLİ ÇENE KISMI NO:1

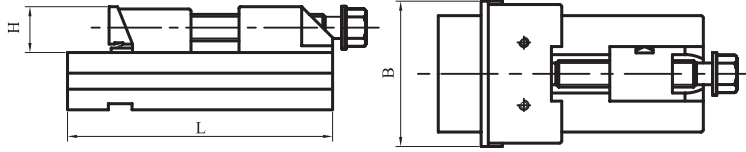

KOD	B (mm)	H (mm)	L (mm)	FİYAT USD
C970M-125I	125	40	160	
C970M-150I	150	50	230	
C970M-175I	175	60	240	
C970M-200I	200	65	300	

MODÜLER SÜPER HASSAS MENGENE SABİT ÇENE KISMI NO:2

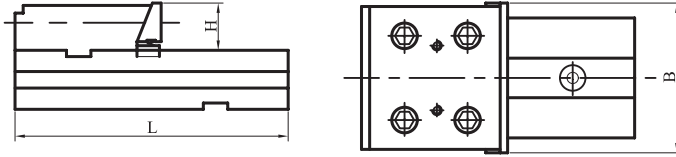

KOD	B (mm)	H (mm)	L (mm)	FİYAT USD
C970M-125II	125	40	160	
C970M-150II	150	50	230	
C970M-175II	175	60	240	
C970M-200II	200	65	300	

MODÜLER SÜPER HASSAS MENGENE ÇİFT TARAFLI SABİT ÇENE KISMI NO:3

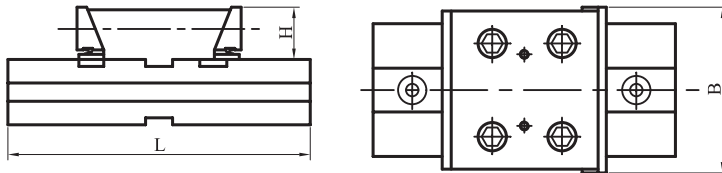

KOD	B (mm)	H (mm)	L (mm)	FİYAT USD
C970M-125III	125	40	160	
C970M-150III	150	50	230	
C970M-175III	175	60	240	
C970M-200III	200	65	300	

FREZE MENGENESİ

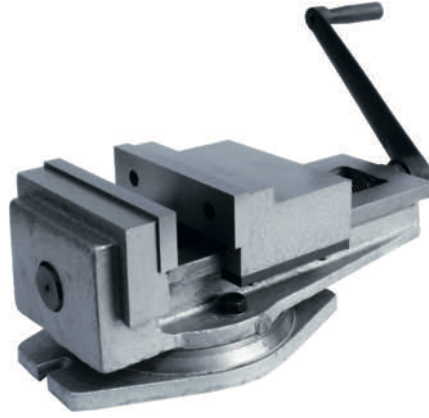

KOD	ÇENE GENİŞLİĞİ (mm)	ÇENE YÜKSEKLİĞİ (mm)	MAX.AÇILMA (mm)	AĞIRLIK (Kg)	FİYAT USD
C906-136	136	36	170	15	
C906-160	160	51	180	22	
C906-200	200	64	220	36	
C906-250	250	64	280	53	
C906-320	320	81	360	77	

HASSAS FREZE MENGENESİ (SÜPER OPEN)

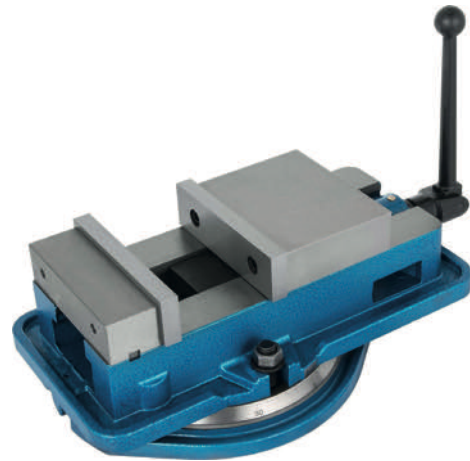
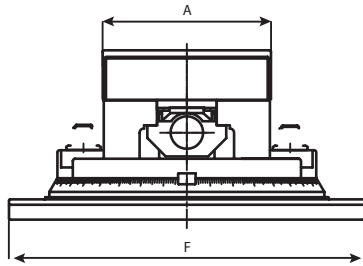
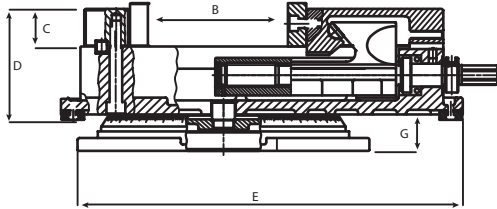

KOD	A (mm)	B (mm)	C (mm)	D (mm)	E (mm)	F (mm)	G (mm)	AĞIRLIK (Kg)	FİYAT USD
C965-160A	161	160	48	112,5	425	300	41,5	45	
C965-160	161	190	48	112,5	425	300	41,5	40	
C965-200	200	218	62	140	550	336	44,5	85	
C965-160T	160 mm MENGENE TABLASI								

3 AÇILI MENGENE



ÖZELLİKLER

- MENGENE 3 DOĞRULTUDA AYARLANABİLİR
- TABLA 360° DÖNEBİLİR
- YATAY-DİKEY YÖNDE 90° HAREKET EDEBİLİR
- SAĞA SOLA HER İKİ YÖNE 45° AYARLANABİLİR
- HER YÖN HAREKETİNDE İŞ PARÇASI SAĞLAM BİÇİMDE TUTULUR
- BÖLGESEL OLARAK VİDANIN KAPANAN KISMI ÖZEL BİR MALZEMEDEN ÜRETİLMİŞ YATAK VASITASIYLA GÜÇLENDİRİLMİŞTİR

KOD	ÇENE GENİŞLİĞİ (mm)	ÇENE YÜKSEKLİĞİ (mm)	MAX.AÇILMA (mm)	AĞIRLIK (Kg)	FİYAT USD
C007-105	105	40	110	31	
C007-125	125	40	125	35	

2 AÇILI MENGENE



ÖZELLİKLER

- AĞIR DÖKME DEMİR GÖVDE
- HER İKİ DOĞRULTUDA ÖLÇEK
- Z DOĞRULTUSUNDA 360° LİK TABLA
- DİKEY VE YATAY 90° LİK HAREKET

KOD	ÇENE GENİŞLİĞİ (mm)	ÇENE YÜKSEKLİĞİ (mm)	MAX. AÇILMA (mm)	AĞIRLIK (Kg)	FİYAT USD
C904-125	125	46	140	31	
C904-160	160	50	125	35	

VİDALI HASSAS MENGENE

ÖZELLİKLER

- YÜKSEK KALİTELİ ALAŞIMLI ÇELİKTEN ÜRETİLMİŞTİR
- PARALELLİK TOLERANSI 0,005 mm / 100 mm
- ÇALIŞMA YÜZEYLERİ 58-62 HRC SERTLEŞTİRİLİP HASSAS TAŞLANMIŞTIR
- HASSAS ÖLÇÜMLERDE, KALİTE KONTROLDE, TAŞLAMA VE ELEKTRO EROZYON TEZGAHLARINDA KULLANILIR

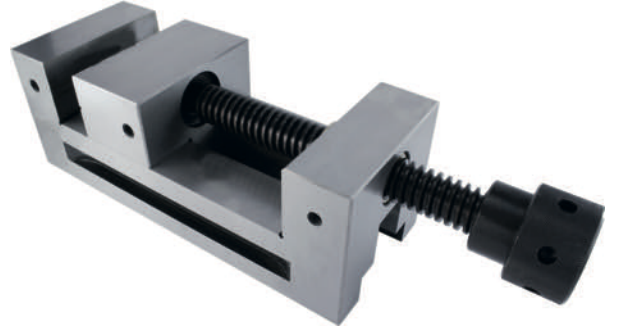
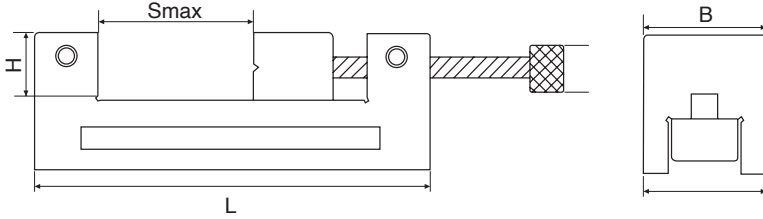

KOD	B (mm)	H (mm)	S max. (mm)	L (mm)	AĞIRLIK (Kg)	FİYAT USD
C905-QGG050	50	25	65	155	3	
C905-QGG073	73	35	100	210	5	
C905-QGG100	100	45	125	260	13	
C905-QGG125	125	50	160	300	19,5	

AÇILI VİDALI HASSAS MENGENE

ÖZELLİKLER

- YÜKSEK KALİTELİ ALAŞIMLI ÇELİKTEN ÜRETİLMİŞTİR
- PARALELLİK TOLERANSI 0,005 mm / 100 mm
- ÇALIŞMA YÜZEYLERİ 58-62 HRC SERTLEŞTİRİLİP HASSAS TAŞLANMIŞTIR
- AÇI KONTROLÜ VE AÇILI İŞLEMLERDE KULLANILIR

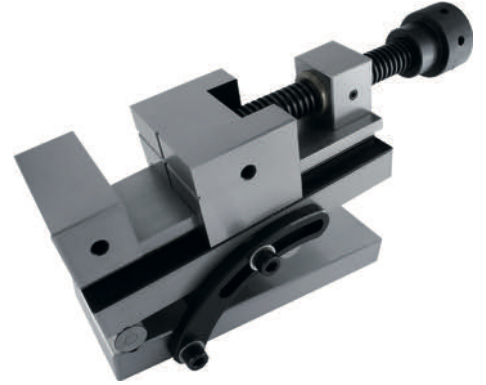
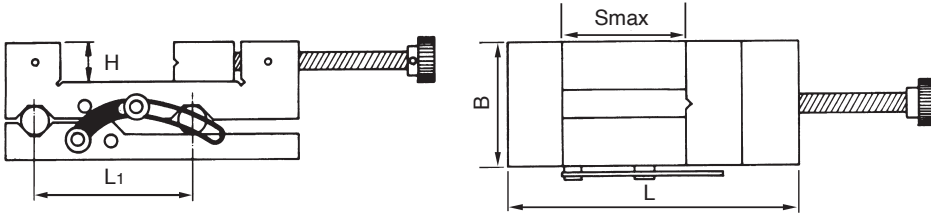

KOD	B (mm)	H (mm)	S max. (mm)	L (mm)	L ₁ (mm)	ÇALIŞMA AÇISI	FİYAT USD
C905-QGJ050	50	25	60	140	100	0~45°	
C905-QGJ073	73	35	90	190	100	0~45°	
C905-QGJ100	100	45	125	245	100	0~45°	
C905-QGJ125	125	50	160	285	200	0~45°	

PİMLİ HASSAS MENGENE

ÖZELLİKLER

- YÜKSEK KALİTELİ ALAŞIMLI ÇELİKTEN ÜRETİLMİŞTİR
- PARALELLİK TOLERANSI 0,005 mm / 100 mm
- ÇALIŞMA YÜZEYLERİ 58-62 HRC SERTLEŞTİRİLİP HASSAS TAŞLANMIŞTIR
- HASSAS ÖLÇÜMLERDE, KALİTE KONTROLDE, TAŞLAMA VE ELEKTRO EROZYON TEZGAHLARINDA KULLANILIR

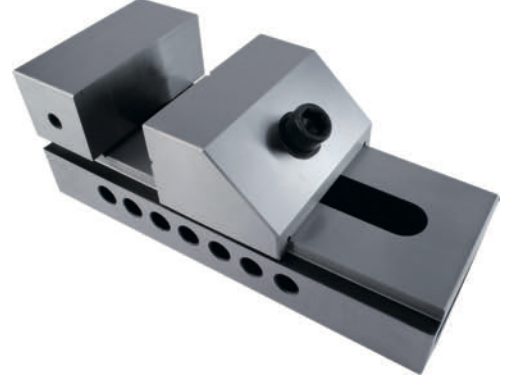
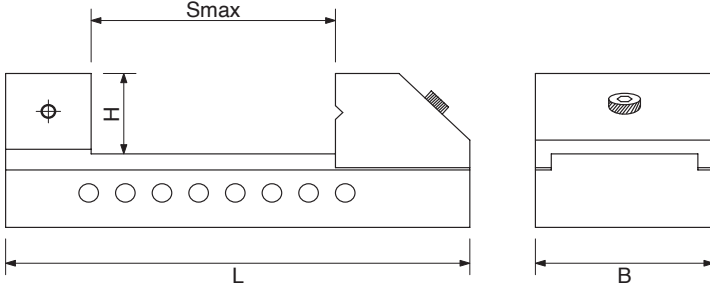

KOD	B (mm)	H (mm)	S max. (mm)	L (mm)	AĞIRLIK (Kg)	FİYAT USD
C905-QKG050	50	25	65	140	3	
C905-QKG073	73	35	100	190	4,1	
C905-QKG100	100	45	125	245	10	
C905-QKG125	125	50	160	285	18	

AÇILI PİMLİ HASSAS MENGENE

ÖZELLİKLER

- YÜKSEK KALİTELİ ALAŞIMLI ÇELİKTEN ÜRETİLMİŞTİR
- PARALELLİK TOLERANSI 0,005 mm / 100 mm
- ÇALIŞMA YÜZEYLERİ 58-62 HRC SERTLEŞTİRİLİP HASSAS TAŞLANMIŞTIR
- AÇI KONTROLÜ VE AÇILI İŞLEMLERDE KULLANILIR

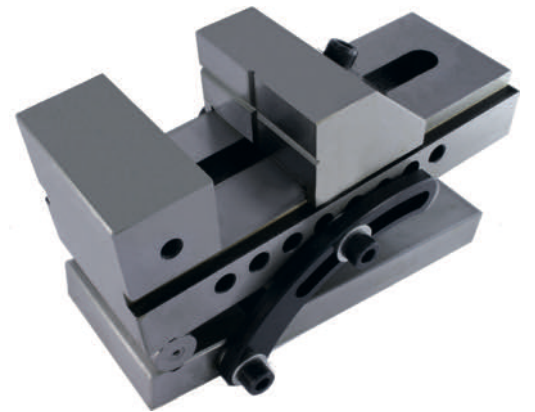
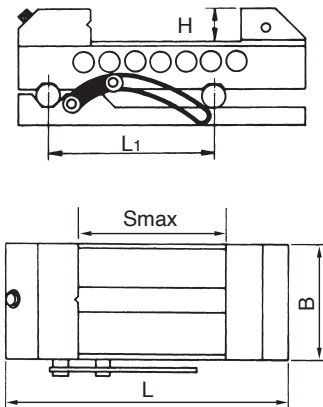

KOD	B (mm)	H (mm)	S max. (mm)	L (mm)	L ₁ (mm)	ÇALIŞMA AÇISI	FİYAT USD
C905-QKJ050	50	25	65	140	100	0~45°	
C905-QKJ073	73	35	100	190	100	0~45°	
C905-QKJ100	100	45	125	245	100	0~45°	
C905-QKJ125	125	50	160	285	200	0~45°	

CNC FREZE MENGENESİ

ÖZELLİKLER

- CNC TEZGAHLARLA TAŞLAMA VE FREZELEME İŞLEMLERİNDE KULLANILIR
- PARALELLİK TOLERANSI 0,025 mm/100 mm
- AÇILI KİLİTLEME SAYESİNDE İŞ PARÇASI SIKMA ESNASINDA YUKARI KAYMAZ



KOD	ÇENE GENİŞLİĞİ (mm)	ÇENE YÜKSEKLİĞİ (mm)	MAX.AÇILMA (mm)	AĞIRLIK (Kg)	FİYAT USD
C964-100	100	34	100	10	
C964-150	150	45	150	26	

ÇİFT ÇENELİ MENGENE

ÖZELLİKLER

- SFERO DÖKÜM DEMİRDEN ÜRETİLMİŞTİR
- ÇALIŞMA YÜZEYLERİ 50-60 HRC SERTLEŞTİRİLMİŞTİR
- AÇILI KİLİTLEME SAYESİNDE İŞ PARÇASI SIKMA ESNASINDA YUKARI KAYMAZ
- PARALELLİK TOLERANSI 0,025 mm / 100 mm
- İKİ İŞ PARÇASI AYNI ANDA SIKILABİLİR
- TEK TEK YA DA YAN YANA BİRKAÇ MENGENE OLARAK KULLANILABİLİR

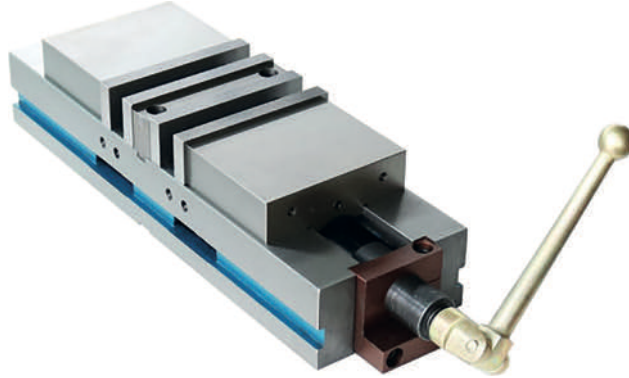

KOD	ÇENE GENİŞLİĞİ (mm)	ÇENE YÜKSEKLİĞİ (mm)	MAX.AÇILMA (mm)	TAM BOY (mm)	AĞIRLIK (Kg)	FİYAT USD
C980-100	100	35	76	390	22	
C980-160	160	50	100	510	43	

AÇILI TABLA

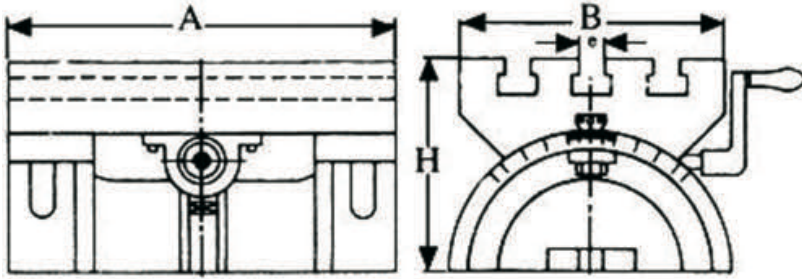

KOD	TABLA			T KANAL	ÇALIŞMA AÇISI	AĞIRLIK (Kg)	FİYAT USD
	A (mm)	B (mm)	H (mm)	e (mm)			
C004-250	254	178	127	12,70	45°	29	
C004-300	304	228	163	12,70	45°	40	

ÇAPRAZ SUPPORT

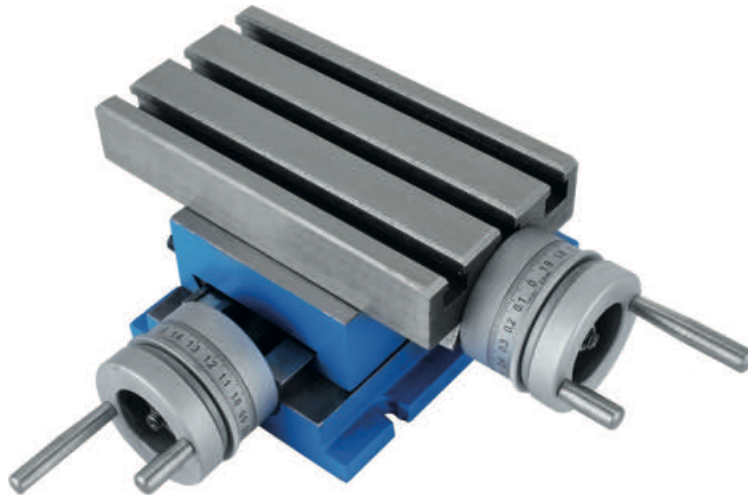

KOD	TABLA ÖLÇÜSÜ (mm)	YÜKSEKLİK (mm)	UZUNLUK (mm)	KANAL ÖLÇÜSÜ (mm)	ÇALIŞMA MESAFESİ (mm)	HASSASİYET (mm)	AĞIRLIK (Kg)	FİYAT USD
C975-220X330	220x330	140	510	11,18	200	0,01	38	



- SEHPA FİYATA DAHİL DEĞİLDİR
- TÜRKÇE MENÜ

SEHPA

KOD	C.KR-DS01
FİYAT USD	

KOD	C.KR-DS12
VOLTAJ	220V/50HZ
MOTOR GÜCÜ	600W
DEVİR	0-1000rpm
ÖLÇÜ	M2-M12
PENSLER	DIN 371 : M2 / M3 / M4 / M5-M6 / M8 / M10 / DIN376 : M12
AĞIRLIK	33 Kg
FİYAT USD	

KOD	C.KR-DS16
VOLTAJ	220V/50HZ
MOTOR GÜCÜ	600W
DEVİR	0-312rpm
ÖLÇÜ	M3-M16
PENSLER	DIN 371 : M3 / M4 / M5-M6 / M8 / M10 / DIN376 : M12 / M14 / M16
AĞIRLIK	33 Kg
FİYAT USD	



- SEHPA FİYATA DAHİL DEĞİLDİR
- TÜRKÇE MENÜ

SEHPA

KOD	C.KR-DS01
FİYAT USD	

KOD	C.KR-DS30
VOLTAJ	220V/50HZ
MOTOR GÜCÜ	1200W
DEVİR	0-180rpm
ÖLÇÜ	M6-M30
PENSLER	DIN 371 : M6 / M8 / M10 / DIN376 : M12 / M14 / M16 / M18-20 / M22 / M24 / M30
AĞIRLIK	53 Kg
FİYAT USD	

KOD	C.KR-DS36
VOLTAJ	220V/50HZ
MOTOR GÜCÜ	1200W
DEVİR	0-150rpm
ÖLÇÜ	M6-M36
PENSLER	DIN 371 : M6 / M8 / M10 / DIN376 : M12 / M14 / M16 / M18-20 / M22 / M24 / M30 / M33 / M36
AĞIRLIK	55 Kg
FİYAT USD	

MATKAP BİLEME MAKİNASI

- PORTATİF MATKAP BİLEYİCİ
- KOLAY KULLANIM, HIZLI VE HASSAS BİLEME
- ÖZEL DONANIMI SAYESİNDE UZUN KULLANIM ÖMRÜ
- MATKAP UÇLARININ ÖZ KISMINDA AÇTIĞI İKİNCİL KESME KENARI SAYESİNDE DELME İŞLEMİNİ KOLAYLAŞTIRIR
- **KARBÜR BİLEME TAŞI İLE BİRLİKTE TESLİM EDİLİR**
- **KARBÜR TAŞ İLE HSS ÜRÜN BİLENMEZ**
- **HSS ÜRÜNLER İÇİN TAŞ TEMİN EDİLEBİLİR**



C.KR-13A



C.KR-26A

YEDEK TAŞLAR	FİYAT USD
HSS (CBN)	
KARBÜR (SDC)	

YEDEK TAŞLAR	FİYAT USD
HSS (CBN)	
KARBÜR (SDC)	



KOD	C.KR-13A	C.KR-26A
MATKAP BİLEME ARALIĞI	Ø2 ~ Ø13	Ø8 ~ Ø30
BİLEME AÇISI	90° ~ 135°	85° ~ 140°
MOTOR	180W	450W
HIZ	5300rpm	4000rpm
GÜÇ	220 VAC	220 VAC
ÇANAK TAŞ	SD	SD
PENS ÖLÇÜLERİ	ER20 PENS Ø4,5,6,7,8,9,10,11,12,13	ER40 PENS Ø12,16,18,20,22,25
PAKET ÖLÇÜLERİ	370x180x190mm	460x240x220mm
AĞIRLIK	10 Kg	27 Kg
FİYAT USD		

FREZE BİLEME MAKİNASI

- PORTATİF FREZE BİLEME MAKİNASI 2, 3, 4 VE 6 AĞIZLI PARMAK FREZELERİN BİLENMESİNE OLANAK SAĞLAR
- DOĞRU VE HIZLI BİLEME
- KOLAY OPERASYON
- TEK BİR BİLEME TAŞI İLE TÜM OPERASYONLARDA UYGULAMA KOLAYLIĞI
- UZUN KULLANIM ÖMRÜ
- **KARBÜR BİLEME TAŞI İLE BİRLİKTE TESLİM EDİLİR**
- **KARBÜR TAŞ İLE HSS ÜRÜN BİLENMEZ**
- **HSS ÜRÜNLER İÇİN TAŞ TEMİN EDİLEBİLİR**



C.KR-X1

YEDEK TAŞLAR	FİYAT USD
HSS (CBN)	
KARBÜR (SDC)	



C.KR-X5

YEDEK TAŞLAR	FİYAT USD
HSS (CBN)	
KARBÜR (SDC)	



KOD	C.KR-X1	C.KR-X5
FREZE BİLEME ARALIĞI	Ø4 ~ Ø14	Ø13 ~ Ø30
BİLEME AÇISI	0° ~ 5°	0° ~ 5°
MOTOR	180W	450W
HIZ	5300rpm	4000rpm
GÜÇ	220 VAC	220 VAC
ÇANAK TAŞ	SD	SD
PENS ÖLÇÜLERİ	ER20 PENS Ø4,5,6,7,8,9,10,11,12,13	ER40 PENS Ø12,16,18,20,22,25
PAKET ÖLÇÜLERİ	320x210x200mm	500x290x300mm
AĞIRLIK	20 Kg	50 Kg
FİYAT USD		

ÜNİVERSAL BİLEME MAKİNASI



ÖZELLİKLER

- HSS VE KARBÜR'DEN ÜRETİLMİŞ NEGATİF AÇILI, RADYÜSLÜ DAHİL ÇOK ÇEŞİTLİ KESİCİ UÇLARIN TAŞLANMASINDA KULLANILIR
- POZİSYONLU UNIVERSAL İNDEKS KAFASI İLE HERHANGİ BİR AÇI VE ŞEKLİN TAŞLANMASINI SAĞLAR
- FREZE, MATKAP, KALEM VS TAŞLANABİLMESİ İÇİN 100-3600 DEVİR ARASI ÇALIŞTIRILABİLİR
- ÖZEL APARATLARIN KURULUMU VE KULLANIMI OLDUKÇA BASİTTİR

KOD	FİYAT USD
C.KR-U2	

KOD	FİYAT USD
U2-E	
U2-T	
U2-L	
U2-D #100	
U2-B KAYIŞ	
U2-G ÇANAK TAŞ	
U2-R #200	
U2-R-1 #400	

MAX. TAŞLAMA ÇAPI Ø25
TEPE AÇISI 0°-180°
KANAL AÇISI 0°- 45°
NEGATİF AÇI 0°-26°
TAŞLAMA MİLİ: 3600 RPM
ÇANAK TAŞ: 100X50X20 mm
MOTOR 1/3 HP 220V50/90HZ
NET AĞIRLIK 45 Kg
BRÜT AĞIRLIK 58 Kg
MAKİNA ÖLÇÜLERİ BxExY 45x40x35 cm
KUTU ÖLÇÜLERİ BxExY 55X45X47 cm

U2-E FREZE BİLEME APARATI	U2-T MATKAP BİLEME APARATI
U2-L TORNA TAKIM TAŞLAMA APARATI	R8 PENS

STANDART AKSESUARLAR

- MATKAP BİLEME APARATI U2-T
- FREZE BİLEME APARATI U2-E
- TAKIM TAŞLAMA APARATI U2-L
- TAŞ DÜZELTME ELMASI 1 PARÇA
- TAŞ FLANŞI (BAĞLI) 1 PARÇA
- ÇANAK TAŞ 1 PARÇA (U2-G)
- PENS Ø4,6,8,10,12 mm 5 PARÇA
- MERKEZLEME ÇUBUĞU 1 PARÇA
- TAHRİK KAYIŞI 1 PARÇA
- KİLİTLEME PİMİ 1 PARÇA
- ALETLER 1 SET

ELMAS ÇANAK TAŞLAR

KOD	ÖLÇÜ	TANE BÜYÜKLÜĞÜ	FİYAT USD
U2-D	100Çx10Ex5Ux20Yx22T	#100	
U2-R	100Çx8Ex2Xx20Y	#200	

U2-D

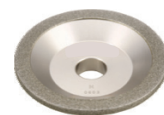

U2-R



UNIVERSAL TAKIM BİLEME MAKİNASI

- 2 ADET YÜKSEK HASSASİYETE SAHİP, DÜZ KAYIT KIZAK SİSTEMİ BULUNMAKTADIR
- SABİT KAYI PLATFORMU SAYESİNDE RAHAT HAREKET İMKANI SAĞLAR
- STANDART AKSESUARLARIYLA MATKAP UÇLARI, PARMAK FREZELER, VALS, TORNALAMA TAKIMLARI, RAYBALAR VB. GİBİ KEŞİCİ TAKIMLARIN BİLENMESİNE OLANAK SAĞLAR
- DAYANIKLI DONANIMI SAYESİNDE DÜŞÜK SERVİS MALİYETİ
- PANTOĞRAF BİLEME İŞLEMLERİNDE KULLANILABİLİR



C.KR-600F

ÖZEL AKSESUARLAR



50E

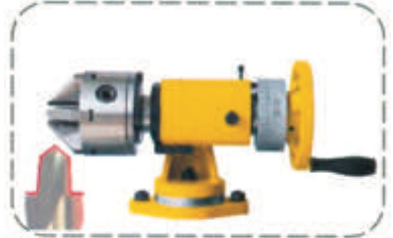

50K



50D



50J



KOD	C.KR-600F	C.KR-600F-50E	C.KR-600F-50K	C.KR-600F-50D	C.KR-600F-50J
TABLA ÖLÇÜSÜ	260mm	-	-	-	-
KURS BOYU	150mm	-	-	-	-
HIZ	2800rpm	-	-	-	-
MOTOR	3/4 HP 220V/380V	-	-	-	-
ÇANAK TAŞ	SDC/CBN	-	-	-	-
PAKET ÖLÇÜLERİ	700x630x630mm	-	-	-	-
BİLEME ARALIĞI	Ø6 ~ Ø25	-	-	-	-
AĞIRLIK	168 Kg	-	-	-	-
FİYAT USD					

EL TİPİ PAH KIRMA MAKİNASI

- TAŞINMASI KOLAY OLMAYAN İŞ PARÇALARININ ISIL İŞLEM GÖRMEMİŞ YÜZEYLERİNDE KOLAYLIKLA UYGULANABİLİR
- KULLANIŞLIDIR VE ZAMANDAN TASARRUF SAĞLAR
- DAYANIKLI DONANIMI SAYESİNDE DÜŞÜK SERVİS MALİYETİ



C.KR-R200

KOD	C.KR-R200
PAH KIRMA ACISI	15° ~ 45°
MOTOR	180W
HIZ	2800rpm
GÜÇ	3/4 HP(750W), 380 VAC
PAH YÜKSEKLİĞİ	0-9mm
PAKET ÖLÇÜLERİ	350x250x200mm
AĞIRLIK	12 Kg
FİYAT USD	

TOZ GEÇİRMEZ HALOJEN LAMBALAR

ÖZELLİKLER

- BOBINLİ DÖNÜŞTÜRÜCÜ DOĞRUDAN AC GÜÇ KAYNAĞINA BAĞLIDIR
- DÜZENSİZ VOLTAJA KARŞI BOBINLİ DÖNÜŞTÜRÜCÜ KULLANILMIŞTIR
- UZUN ÖMÜRLÜDÜR
- KOL KISMI SU GEÇİRMEZDİR
- BORU TİPİ KOL, GENİŞ AÇILI AYDINLATMA SAĞLAR



KHL-300S
KISA KOL



KHL-300M
ORTA BOY KOL (250x200mm)



KHL-300L
UZUN KOL (430x400mm)

KOD	GİRİŞ VOLTAJI	LAMBA	MONTAJ	AĞIRLIK (kg)	FİYAT USD
KHL-300L	24 V	50W (Halojen)	MANYETİK TABAN	4.4	
KHL-300M	24 V	50W (Halojen)	MANYETİK TABAN	3.6	
KHL-300S	24 V	50W (Halojen)	MANYETİK TABAN	2.9	

52 PARÇA KALIP BAĞLAMA SETİ



SET İÇERİĞİ

- 24 ADET SAPLAMA (75/100/125/150/175/200 mm)
- 6 ADET T-SOMUN
- 4 ADET EŞLEŞME SOMUNU
- 6 ADET FLANŞ SOMUNU
- 6 ADET PABUÇ KİLİDİ
- 6 ADET PABUÇ BLOĞU

KOD	TABLA YUVASI	CİVATA ÖLÇÜSÜ	AĞIRLIK (Kg)	FİYAT USD
C750-58M10	12	M10-1.5P	7,6	
C750-58M12	14	M12-1.75P	9,5	
C750-58M14	16	M14-2.0P	11,1	
C750-58M16	18	M16-2.0P	12,7	
C750-58M18	20	M18-2.5P	25,3	

YUVARLAK MANYETİK TABLA

12 KGF



KOD	ÖLÇÜ (mm)	YÜKSEKLİK (mm)	TUTMA KUVVETİ	FİYAT USD
C009-160	160	50	12 Kg/cm ²	
C009-200	200	55	12 Kg/cm ²	
C009-250	250	80	12 Kg/cm ²	

KUVVETLİ MANYETİK TABLA

12 KGF

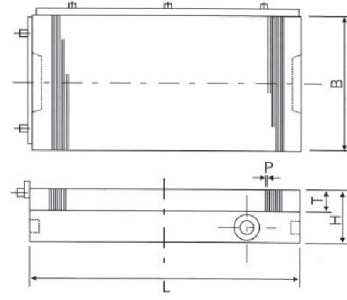

KOD	B (mm)	L (mm)	H (mm)	T (mm)	P (mm)	TUTMA KUVVETİ	NET AĞIRLIK	FİYAT USD
						(N/cm ²)	(Kg)	
C001-1530X41	150	300	48	20	0.5+1.5	≥120	16,8	
C001-2040X41	200	400	53	22	0.5+1.5	≥120	31,8	
C001-2050X41	200	500	53	22	0.5+1.5	≥120	41,6	
C001-2060X41	200	600	53	22	0.5+1.5	≥120	50	
C001-2550X41	250	500	58	23	0.5+1.5	≥120	53,5	
C001-3050X41	300	500	58	23	0.5+1.5	≥120	68,5	
C001-3060X41	300	600	58	23	0.5+1.5	≥120	77	
C001-3080X41	300	800	58	23	0.5+1.5	≥120	109	

ELEKTROMANYETİK TABLA



KONTROL ÜNİTESİ FİYATA DAHİLDİR
MANYETİK TABLALAR KONTROL ÜNİTESİZ KESİNLİKLE ÇALIŞTIRILAMAZ

ÖZELLİKLER

- ÇOK KUVVETLİ TUTUCU MANYETİK TABLA, FREZELEME VE TAŞLAMA İŞLEMLERİNDE İŞ PARÇASI İŞLEMELERİ İÇİN KULLANILIR
- AÇIK POZİSYONDA GÜÇ KESİLSE BİLE UZUN SÜRE MANYETİK ÖZELLİĞİNİ KORUYARAK ÇALIŞMAYA DEVAM EDER
- EN GÜÇLÜ MAKİNA TAKIMLARI İÇİN BİLE UYGUNDUR
- İŞ PARÇASINI TUTARKEN DIŞ GÜÇ KAYNAKLARINDAN TAMAMEN BAĞIMSIZDIR. ELEKTRİK KESİNTİLERİNDE TAMAMEN GÜVENLİDİR
- HASSASİYETİ SICAKLIKTAN ASLA ETKİLENMEZ
- İŞ PARÇASININ BAĞLANMASI ÇOK KOLAY VE UYGUNDUR, KISA SÜREDE BAĞLANIR
- ORTA ,BÜYÜK VE SERT PARÇALARDA BİLE AĞIR İŞLEMELERİNE UYGUNDUR
- TABLA İÇİN ÜZERİNDE YAPILAN İŞLEME GÖRE UYGUN BLOKLAR İSTEĞE GÖRE TEMİN EDİLİR

KOD	UZUNLUK (mm)	GENİŞLİK (mm)	YÜKSEKLİK (mm)	KUTUP SAYISI	AĞIRLIK (Kg)	FİYAT USD
C001-329392	329	392	68	16	65	
C001-491392	491	392	68	24	95	
C001-609392	609	392	68	32	125	
C001-771392	771	392	68	40	155	

MANYETİK KALDIRAÇ

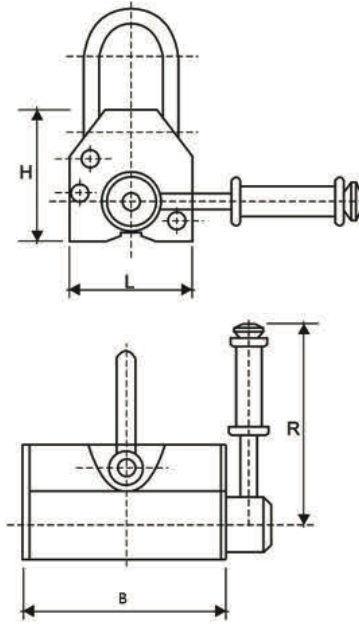

YEDEK KOL

KOD	KAPASİTE (Kg)	FİYAT USD
C990-0100K	100	
C990-0300K	300	
C990-0600K	600	
C990-1000K	1000	
C990-2000K	2000	
C990-3000K	3000	
C990-5000K	5000	

KOD	KAPASİTE (Kg)	L (mm)	B (mm)	H (mm)	R (mm)	MAX. ÇALIŞMA SICAKLIĞI (°C)	EMNİYET KATSAYISI	AĞIRLIK (Kg)	FİYAT USD
C990-0100	100	50	70	70	180	<80	2,5:1	7	
C990-0300	300	90	158	90	190	<80	2,5:1	10	
C990-0600	600	115	200	115	260	<80	2,5:1	21	
C990-1000	1000	130	260	140	310	<80	2,5:1	35	
C990-2000	2000	150	350	160	390	<80	2,5:1	65	
C990-3000	3000	150	430	160	480	<80	2,5:1	100	
C990-5000	5000	210	600	210	700	<80	2,5:1	145	

EKONOMİK TİP MANYETİK KALDIRAÇ

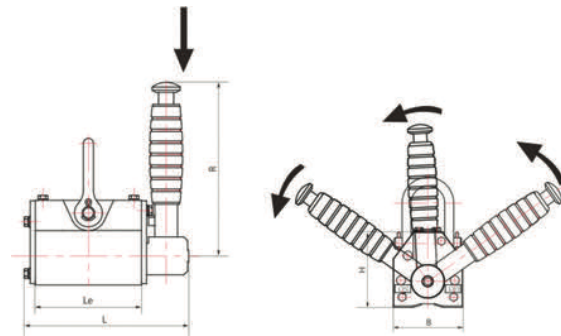

KOD	KAPASİTE (Kg)	Le (mm)	L (mm)	R (mm)	B (mm)	H (mm)	AĞIRLIK (Kg)	FİYAT USD
C991-0300	300	165	195	210	85	95	11	
C991-0600	600	215	255	250	108	120	21	
C991-1000	1000	262	310	280	143	140	38	
C991-2000	2000	345	395	365	150	165	65	

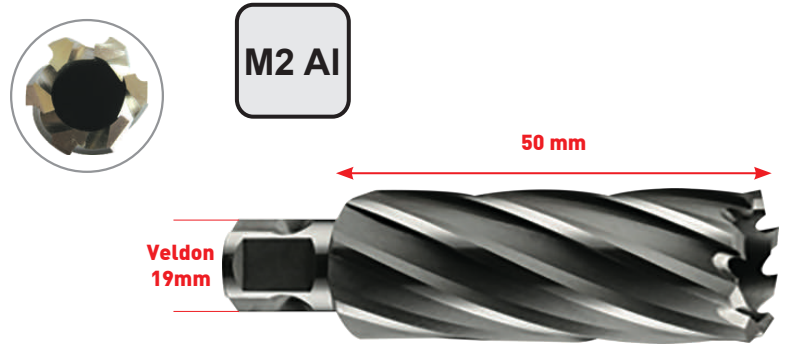
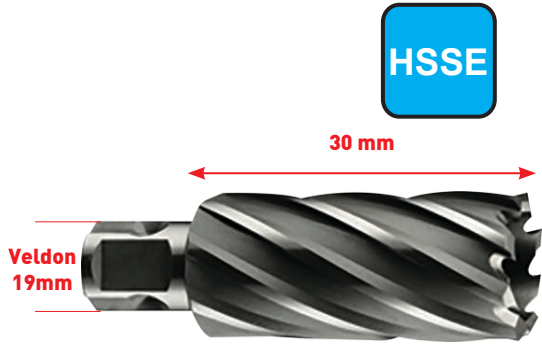

ÇAP (mm)	FİYAT USD	ÇAP (mm)	FİYAT USD
12		37	
13		38	
14		39	
15		40	
16		41	
17		42	
18		43	
19		44	
20		45	
21		46	
22		47	
23		48	
24		49	
25		50	
26		51	
27		52	
28		53	
29		54	
30		55	
31		56	
32		57	
33		58	
34		59	
35		60	
36			

ÇAP (mm)	FİYAT USD	ÇAP (mm)	FİYAT USD
12		37	
13		38	
14		39	
15		40	
16		41	
17		42	
18		43	
19		44	
20		45	
21		46	
22		47	
23		48	
24		49	
25		50	
26		51	
27		52	
28		53	
29		54	
30		55	
31		56	
32		57	
33		58	
34		59	
35		60	
36			

MANYETİK MATKAP SABİTLEME PİMİ

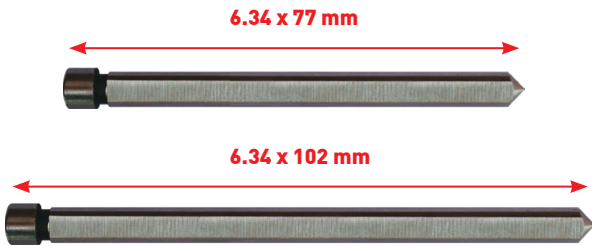

BOY	FİYAT USD
30mm (İÇİN)	
50mm (İÇİN)	

MANYETİK MATKAP MANDREN ADAPTÖRÜ

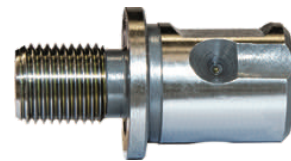

BOY	FİYAT USD
1/2"-20	
5/8"-16	